

UVENCE furniture

designed and made in Vancouver

Uvence furniture is a design driven studio that develops products for the home with respect to the environment.
Certified materials and non toxic finishes.

HECTOR UVENCE

Born in Vancouver and raised in Mexico, Hector completed his studies in Vancouver where he graduated with a Bachelors Degree in Industrial Design from Emily Carr Institute in 2004. His interest in the field of furniture compelled him to design several furniture pieces during his academic years. During this period, a ready-to-assemble chair was chosen to travel to home shows in Denver, Santa Clara, Toronto, and Vancouver as part of a project called "Lesser-Used Wood Species" sponsored by Forintek Corp. Canada. Upon graduation Hector continued to design, develop and fabricate a line of flat packed furniture which featured clean and simple lines with an emphasis on the minimal use of components and computer controlled fabrication.

Hector's passion for furniture lead him to create Uvence Modern Furniture, a collection of pieces that are designed and made in Vancouver with solvent free finishes and certified wood.

In the summer of 2004 Hector received an honorable mention for his entry on Core77 + Catia Napkin Sketch Competition in which over 750 sketches from 65 countries were submitted.

In 2005 Hector and Designer Emma Letho won the bid to design and fabricate the prestigious Vancouver Arts Awards, whose recipients include such distinguished winners as celebrated Canadian author Douglas Coupland, renowned Chef Michel Jacob, and avant-garde architect Peter Busby. The collaboration effort delivered the most innovative awards trophies to date.

In 2006 a prototype of Hector's Linea chair was published by Sense World Wide, London UK in a project called "I Love my Chair".

In 2008 Hector's wine base was showcased at the Piemonte "I Share" festival in Torino, Italy as part of Ponoko's exhibit.

From 2007 to 2009 Hector assisted distinguished Designer Ami McKay with the design development of her eco-friendly line of furniture called "PURE". McKay is renowned for her role on HGTV Canada's Make over Whish.

Currently, Hector continues to develop designs which focus on sustainable practices, as well as contributing to Vancouver's local design industry. Examples of his latest pieces include the "VITO" line made out of red oak hardwood, as well as "Momo" a sofa that features eco-conscious materials and finishes.

There is no such thing as a green product. All products use energy and create waste.

The best we can do is to make products **Greener.**

How?

DURABILITY

Well made products can be repaired and are less likely to end up in the landfill. Durable furniture that will last a long time can be passed on from person to person.

LOW-TOXICITY

When you buy a new product or piece of furniture, it doesn't just sit there. No matter what material it is made of, chances are, it will release substances into the air. Many products are treated with synthetic substances that can release chemicals which are toxic. Volatile organic compounds, or VOCs, are the most common family of chemicals that are released and increased exposure to these substances have been linked to birth defects, endocrine disruption, and cancer. Fortunately, many advancements have been made in non-toxic materials and finishes, and a wide array of high-quality, solvent free products are now available.

LOCALLY MADE

Just like the food on our dinner table, we might be amazed by how many kilometers a piece of furniture has travelled in order to reach us. If possible, source furniture closer to home. This will support the local economy, small businesses and local craftspeople, and decrease the environmental cost of shipping. We can make greener choices that help shape and protect the planet that we cherish.

3.0 WINE RACK

Inspired by the shape of wooden wine barrels, wine rack 3.0 offers an elegant and simple solution to showcase wine bottles.

Laser cnc technology is used for fabrication and the wine rack is hand-finished and solvent-free.

No hardware is necessary for assembly, and packs flat for shipping.

L: 15.5 D: 8 inches.



VITO

Vito line features modern solid red oak hardwood pieces that are built to last. Mortise and tenon joinery and non solvent high quality finishes.



VITO^{STOOL}

Versatile design that can be used as a stool, side table and modules can be arranged as a coffee table.

Red Oak solid hardwood.
Mortise and tenon joinery.
Finishes: clear matt or Ebony stain.
Finishes are based on natural vegetable oils and waxes.

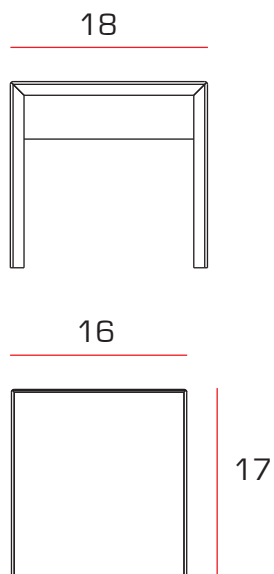

VITO

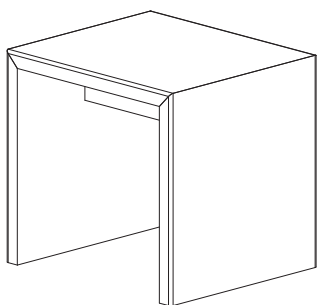

STOOL
H: 17 D:16 L:18"

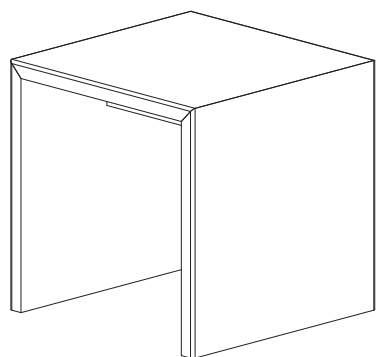

SIDE TABLE
H:20 D:20 L:20"

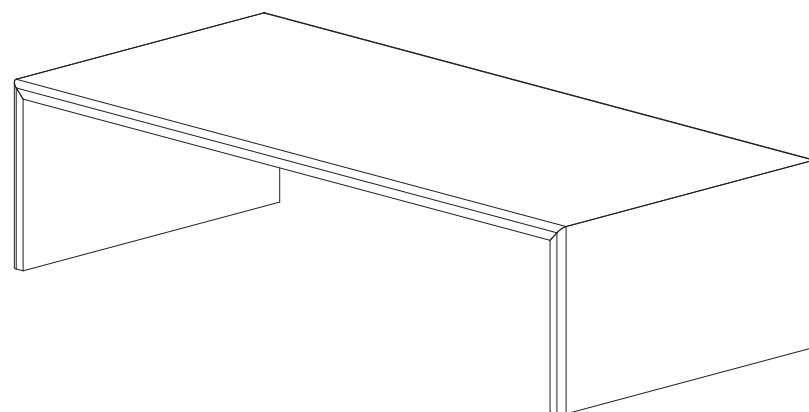

COFFEE TABLE
H:15 D:28 L:60"

Louis XV

Baroque and Rococo inspired mirror.
Laser cut 6 mm. acrylic mirror.
H: 36 W: 24 inches.

Customization available.



MOMO SOFA



Customize your own sofa with British Columbia hardwood frames or plywood. Non toxic adhesives and attention to ergonomics.
SOFA H:32 D:40 L: 80 inches. CHAIR H:32 D:40 L:35 inches.

THANK YOU

For more information and custom
made pieces visit:
www.hectoruvence.com
tel: 604-767-5447
Vancouver, BC. CANADA.

© Uvence furniture 2010